

METASYS

GB **Central Suction System
EXCOM hybrid 1**

Equipment Logbook

Assembly, operation and maintenance

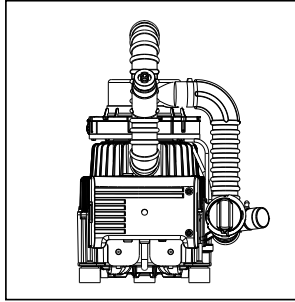

Index

Explanation of the pictograms

1. Index

The footnote found on each page defines the user group particular information is aimed at.

	Page
1. Index	2
2. Explanation of the pictograms	2
3. General Information	3
4. Use	4
5. Type overview	4
6. Construction	5
7. Accessories	6
8. Explanation of the type plate	7
9. Technical data	8
10. Description of function	9
11. Installation guidelines	10
12. Hose connections	11
13. Electrical connections	12
14. Connection ECO II with EXCOM hybrid 1	14
15. Maintenance, cleaning and disinfection	15
16. Commissioning	16
17. Maintenance	17
18. Disposal of the equipment	17

2. Explanation of the pictograms:



Caution!



General warning sign

General information

3. General information



The safety, reliability and performance of the appliance is only guaranteed by METASYS if the following instructions are observed:

- Assembly, alterations or repairs may exclusively be carried out by authorized service personnel in compliance with EN Standard 60601-1 (International Standard for Medical Electrical Apparatus, in particular Part 1: General Rules for Safety).
- The electrical installation must comply with the regulations of the IEC (International Commission for Electrical Engineering).
- The apparatus must exclusively be used in conformity with the instructions for installation, operation and maintenance.
- Only original parts may be used for repairs or replacements.
- All instructions issued by manufacturers of equipment for the treatment of patients which is connected to the suction engine must be observed.
- Following the commissioning of the apparatus, the Installation Proof must be completed and returned to METASYS in order to establish the guarantee period.
- Every inspection and servicing must be recorded in the Equipment Logbook.
- When requested by an authorized engineer, METASYS agrees to make all documents available for the use of technically qualified service personnel.
- METASYS accepts no responsibility for damages caused due to external factors, such as wrong installation, improper use of the apparatus or unauthorized technical intervention.
- Users must study equipment and assure themselves of its good condition before every use.



The equipment is not suitable for use in explosive or combustible environment.

Use Type overview

4. Use:

The METASYS EXCOM hybrid 1 is a central suction system used for centralised vacuum production, as well as the separation of air and liquids in dentistry.

The EXCOM hybrid 1 central suction system is a vacuum engine with integrated separation. It can be operated both as semi-wet or dry suction system.

5. Type overview:

1 EXCOM hybrid 1 - 230 V

EXCOM hybrid 1 is a central suction system with integrated air/water separation for simultaneous operation of 1 treatment unit or for up to 2 treatment units with 60% efficiency.

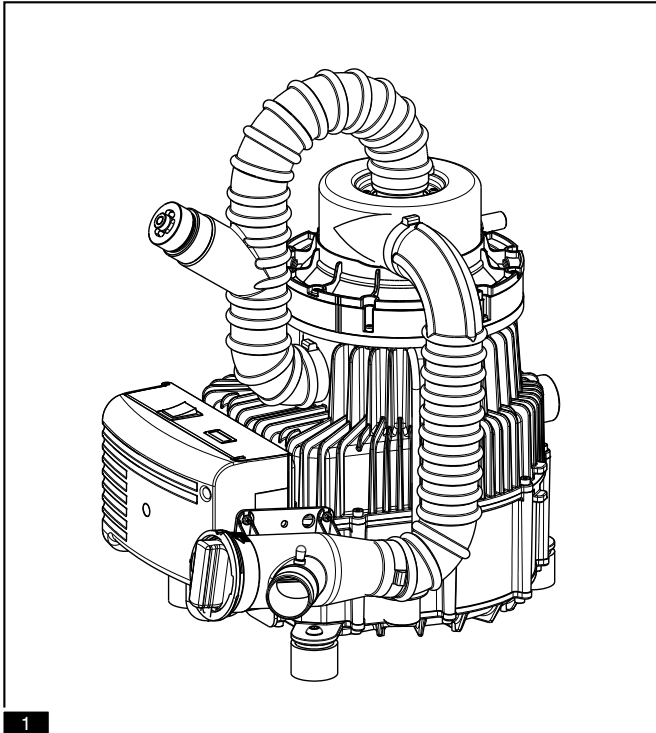

Construction

6. Construction:

2 See illustration

2.1 Suction engine with dynamic separation unit

The suction engine is a powerful dry vacuum engine operating according to the principle of the side channel vacuum pump. The dynamic separation unit centrally separates liquids and solids from the air stream without interruption of the suction's output. This eliminates the need for a separator in the treatment unit.

2.2 Control unit

The control unit contains all electrical components necessary to control and monitor the entire device.

2.3 Air inlet valve + noise reducing item

The air inlet valve optimises the vacuum and protects the suction equipment from overheating. To prevent noise formation at the air inlet valve attach the noise reducing item included in the scope of delivery.

2.4 Prefilter

Coarse solid particles are held back in the prefilter.

2.5 Hose connections

2.6 Water collector

The water collector protects the suction pump from water backdraft and transports the water to the outlet, if necessary.

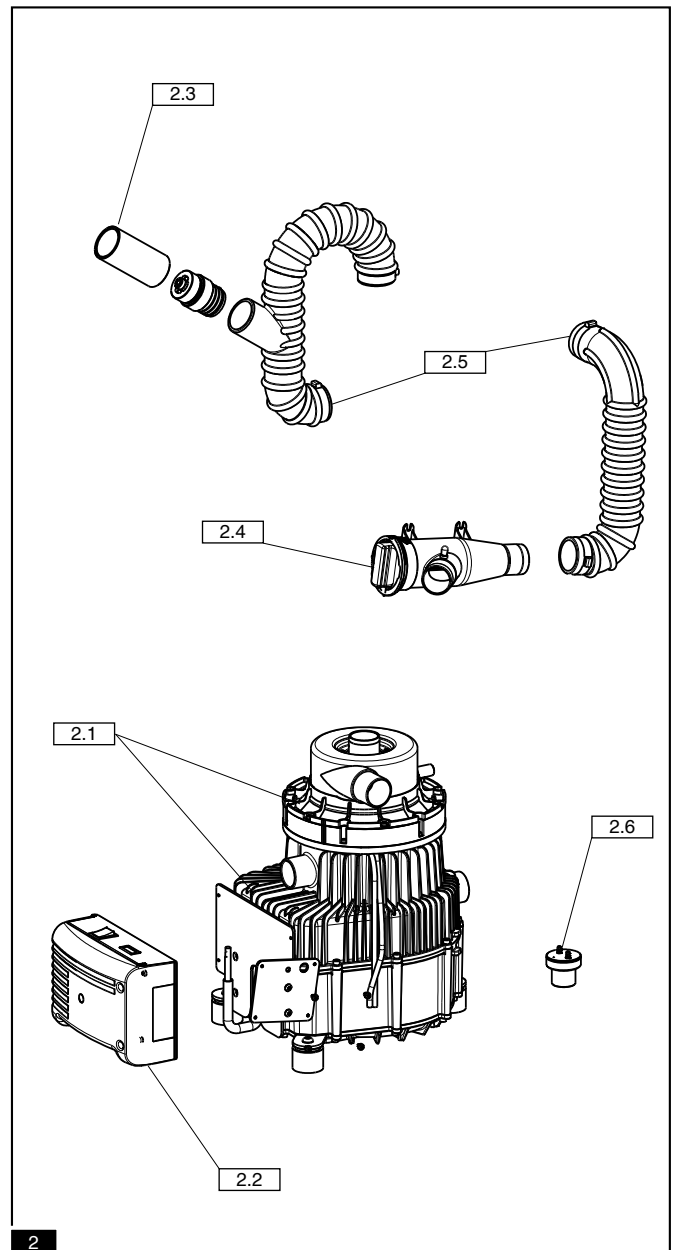

GB

Accessories

7. Optional accessories available:

1 See illustration

External place selection valve

Order number: 40050048

Without integrated selective control air can be entrained through unused open hose connection points of operating suction systems. Distracting noises and loss of suction power can be the result. The installation of a place selection valve prevents this effect.

2 See illustration

Spittoon valve

Order number: 40050002

If the treatment unit has a spittoon bowl, the water from the bowl must be discharged through the suction hose. The installation of a spittoon valve prevents distracting sucking noises and loss of suction through the bowl. The spittoon valve operates automatically and sets off the central suction system.

3 See illustration

Covering hood for EXCOM hybrid 1

Order number: 40040010

The covering hood minimizes the sound level from the vacuum motor and protects the suction system from external influences.

4 See illustration

Air bio filter for EXCOM hybrid 1

Order number: 40060002

For reasons of hygiene and noise reduction we recommend the integration of an air bio filter into the air-discharge connection and to lead it out of doors.

5 See illustration

Noise reducing item for air inlet valve

(included in scope of delivery)

Order number: 40040007

The noise reducing item minimizes the sound level of the air inlet valve.

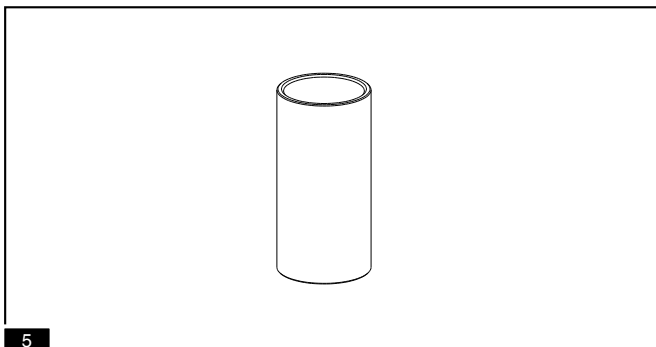
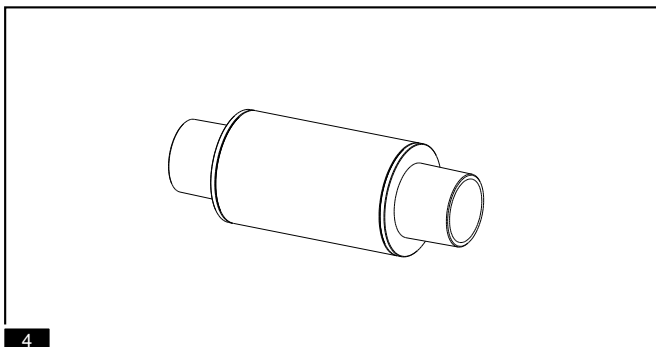
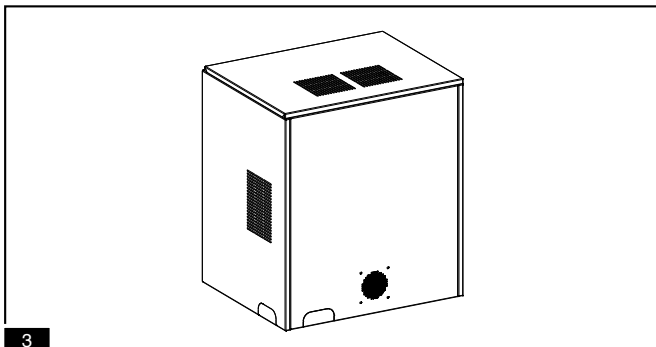
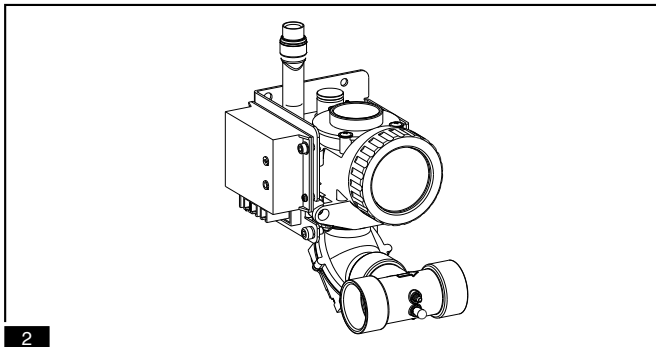
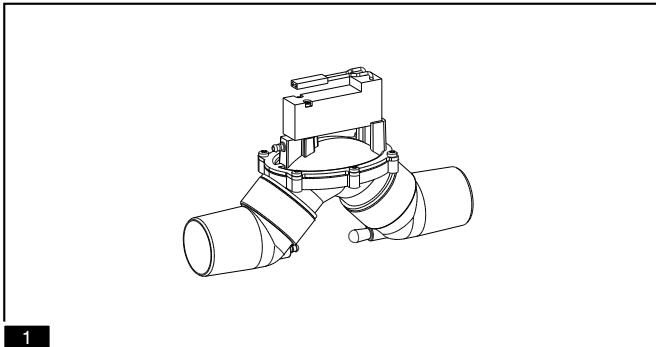

Explanation of the type plate

8. Explanation of the type plate:

6 See illustration

The type plate can be found at the outside of the suction motor 6.1.

7 See illustration

7.1 Equipment type

7.2 Mains supply data

7.3 Serial number

7.4 Address of the manufacturer

7.5 CE conformity mark

7.6 Separate collection electrical/electronic equipment

7.7 ÜZVO conformity mark

7.8 Protection class 1

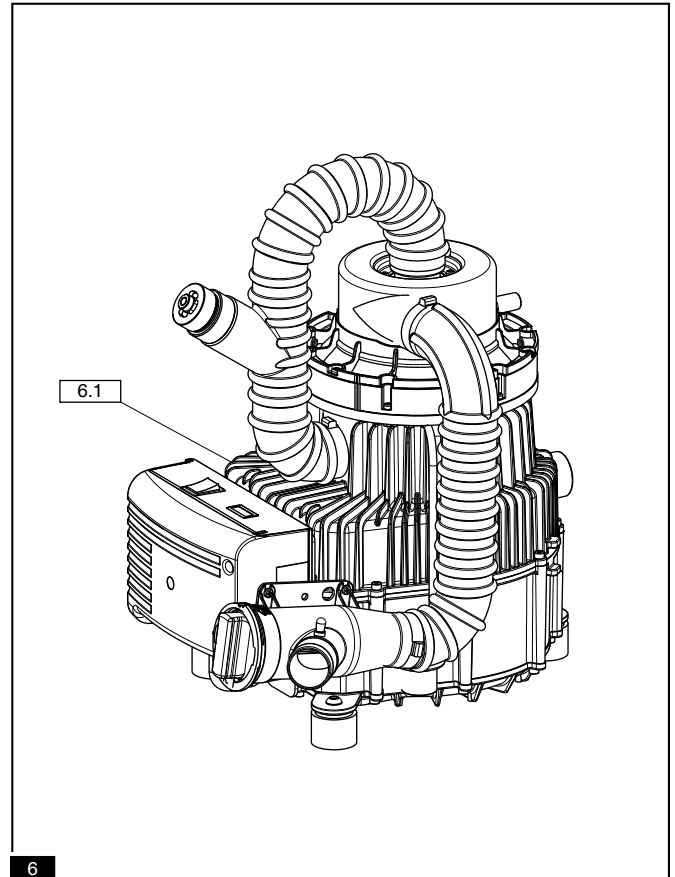

6

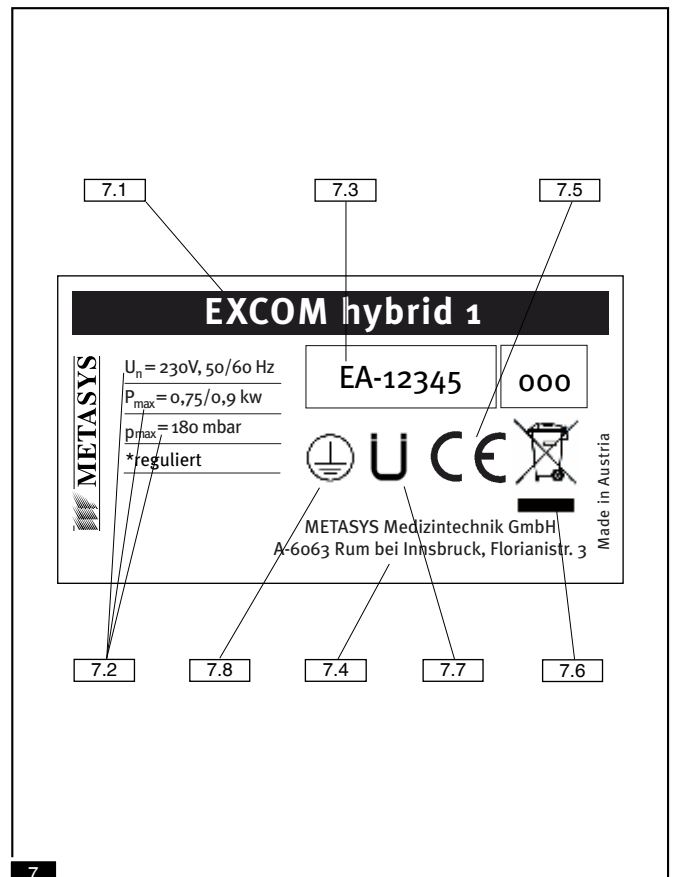

7

GB

Technical data

9. Technical data:

1 EXCOM hybrid 1 - 230 V

Mains voltage	230 V AC
Frequency	50/60 Hz
Max. current consumption	3.3 / 4.1 A
Max. electrical shaft power	0.75 / 0.9 kW
Max. ambient temperature	40° C
Air flow rate	1100 l/min
Negative pressure regulated	180 mbar
Operating time	100 %
Weight	25.3 kg
Noise level	63 dB(A)
Dimensions (L x W x H) mm	460 x 367 x 504

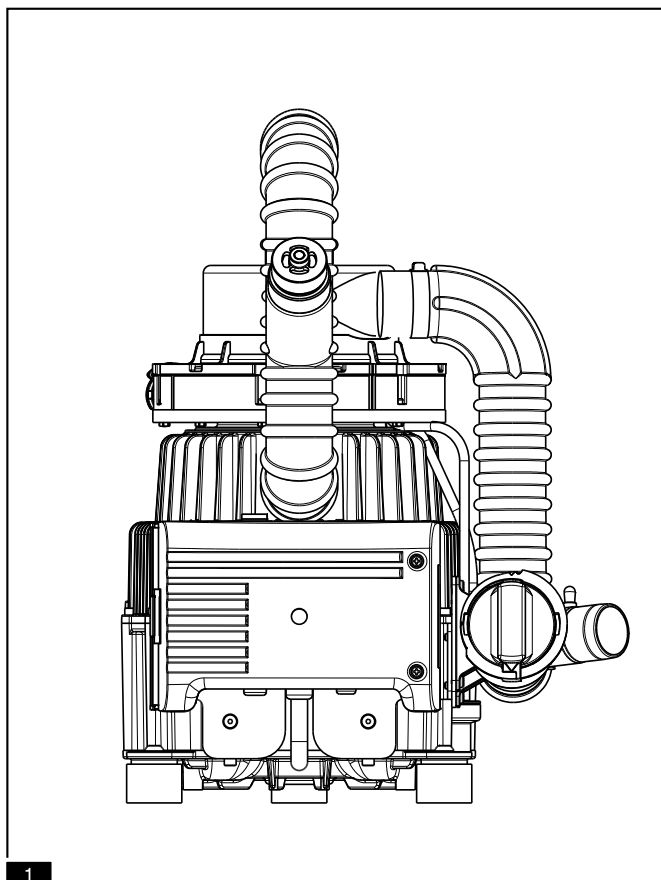

1

GB

Description of function

10. Description of function:

2 See illustration

On removing a suction hose from its rest in the treatment unit, the dynamic separation [2.1] and the EXCOM hybrid 1 central system suction engine [2.2] start. After the vacuum has been developed, the optionally available place selection valve for the treatment place in use opens. The water from the cuspidor or spittoon runs through the spittoon bowl into the suction hose, which also starts the EXCOM hybrid 1 central suction system.

The mixture of liquids, solids and air sucked from the treatment units flows through the suction connection [2.3] and prefilter [2.4] into the separation chamber [2.1]. The mixture is accelerated into a circular movement by the rapidly rotating impeller blades. The liquids and solids are tangentially centrifuged, whilst the air flows through the blade shafts into the hose connection with the air inlet valve [2.5] into the suction engine [2.2]. The dry air is discharged via the optional bio filter into the atmosphere through the exhaust air connection [2.6]. The factory-made follow-up time of the dynamic air / water separation and of the suction motor is ca. 60 seconds. This can be extended according to the installation situation.

The centrifuged liquids and solid particles smaller than the mesh of the prefilters [2.4] are either led into the normal sewage system via the water outlet [2.7] and the drainage connection or directed into an amalgam separator (METASYS ECO II).

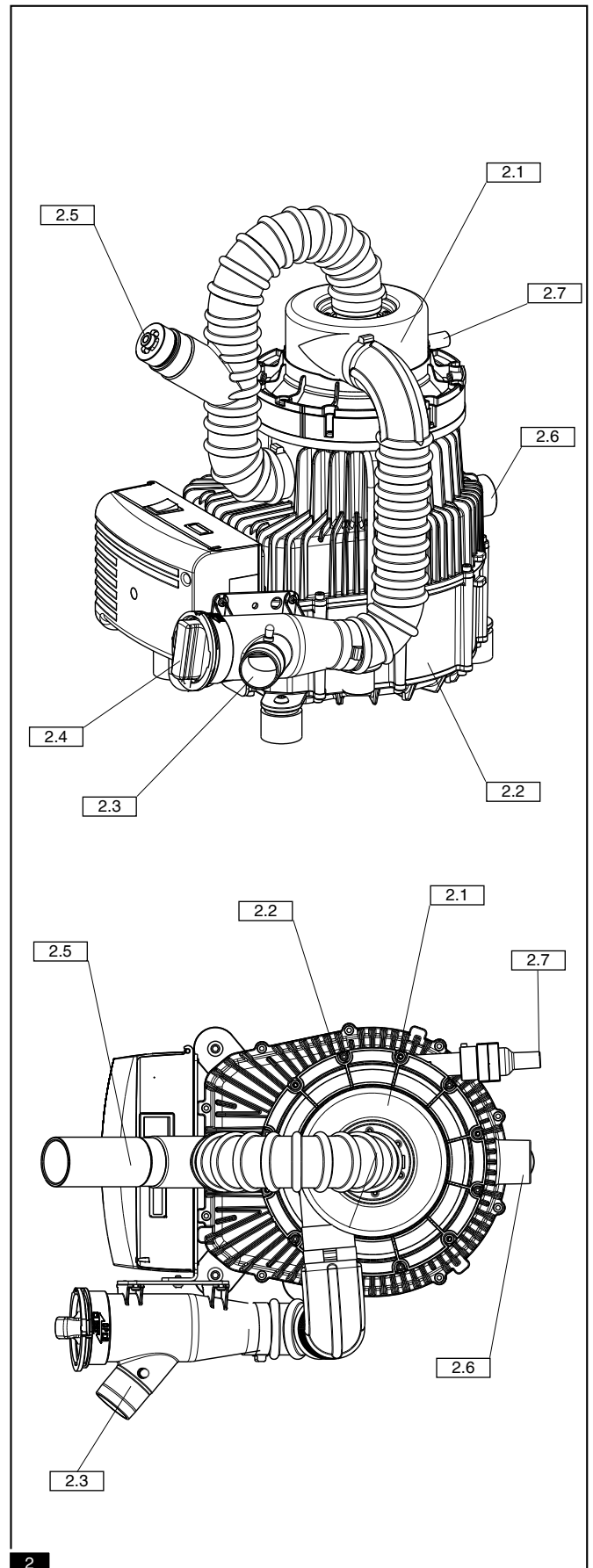

GB

Installation guidelines

11. Installation guidelines:

- The EXCOM hybrid 1 suction system is designed to be installed only in dry, adequately ventilated rooms.



Its use in areas subject to explosive and fire hazards is not permitted.

- The permitted room temperature ranges from between +10°C and +40°C. The relative humidity must not exceed 70%.
- In case of a room temperature of more than +35°C, a fan must be installed for additional ventilation.
- Installation can be on the same level as the treatment units, in a side room or one floor lower.
- In order to avoid vibrations, the suction system must be installed on a firm base.

1 See illustration

When the EXCOM hybrid 1 suction system is installed, the connection side must be placed at least 15 cm from the wall so that the hoses can be connected.

2 See illustration

The front of the device must be easily accessible. If the EXCOM hybrid 1 is installed with the covering hood, nothing must be placed on top of it. To allow the removal of the covering hood, a free space above equal to the equipment's height equal to half its width at the sides is required. There must be clear space of approx. 5 cm around the device to guarantee adequate air circulation.



Do not lift the device at separation!
While the suction is used, the device must not be switched off at the main switch!

3 Air inlet valve (order no: 40040006)

The suction power of a central suction system can fluctuate if only the spittoon valve without a suction cannula is operated. This can affect the transport of the liquids. To optimize the transport of liquids, an air inlet valve needs to be installed in the dental unit. This ensures an air flow of approx. 100 l/min during operation. This measure guarantees the safe transport of waste water from the spittoon bowl through the suction pipes.

Pipe and hose installation:



Any pipe or hose used must be vacuum tight and resistant to all chemicals normally used in a dental practice (e.g. HT discharge pipes made from PP, PVC-C, PVC-U, PE-HD).

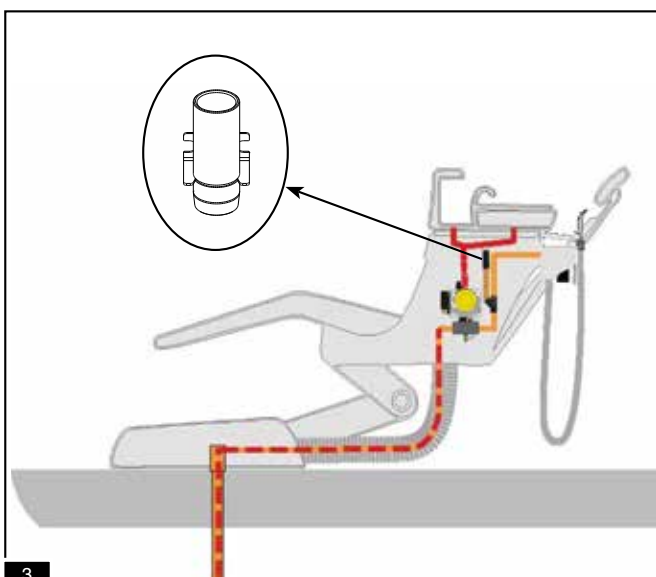
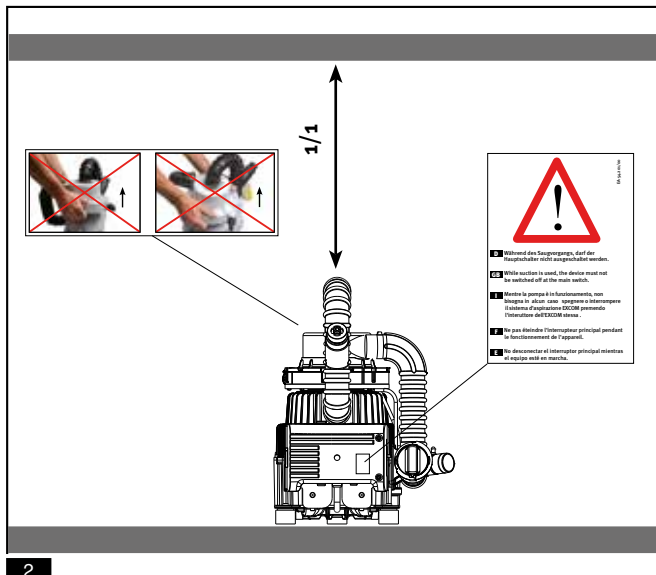
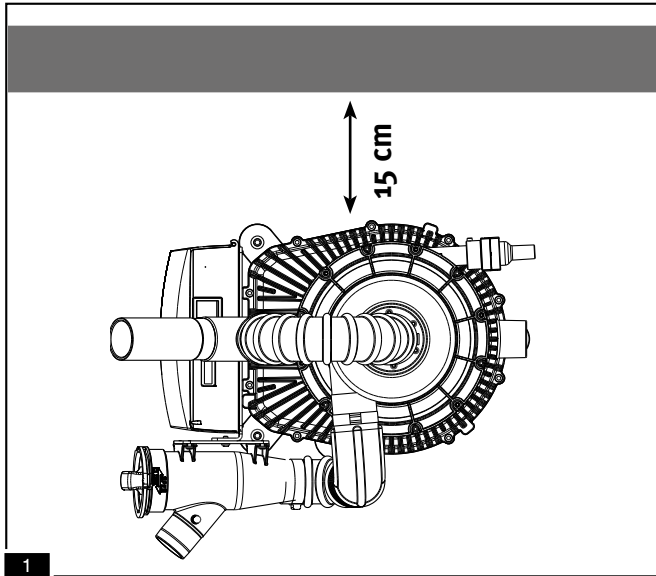

Installation guidelines

Hose connections

11. Installation guidelines:

4 See illustration

- Only flexible spiral hoses made from PVC or equivalent materials may be used.
- Connections to the EXCOM hybrid 1 central suction system must be made by flexible hoses and be as short as possible.
- We recommend a pipe diameter of 40 mm. Avoid right-angle bends in order not to lose suction power (recommendation: 2 x 45° degree bends).
- Discharge pipes must meet applicable local legislation or DIN 1986, Parts 1 and 2.
- Waste water must be allowed to drain off freely without any backup. Waste water pipes must have a hydraulic gradient of at least 2%.
- The air must be discharged out-of-doors. For reasons of hygiene and in order to avoid noise pollution we recommend that the outgoing air connection is fitted with a bio filter.
- The diameter of the discharged air connection must be equal to or bigger than the diameter of the suction connection.

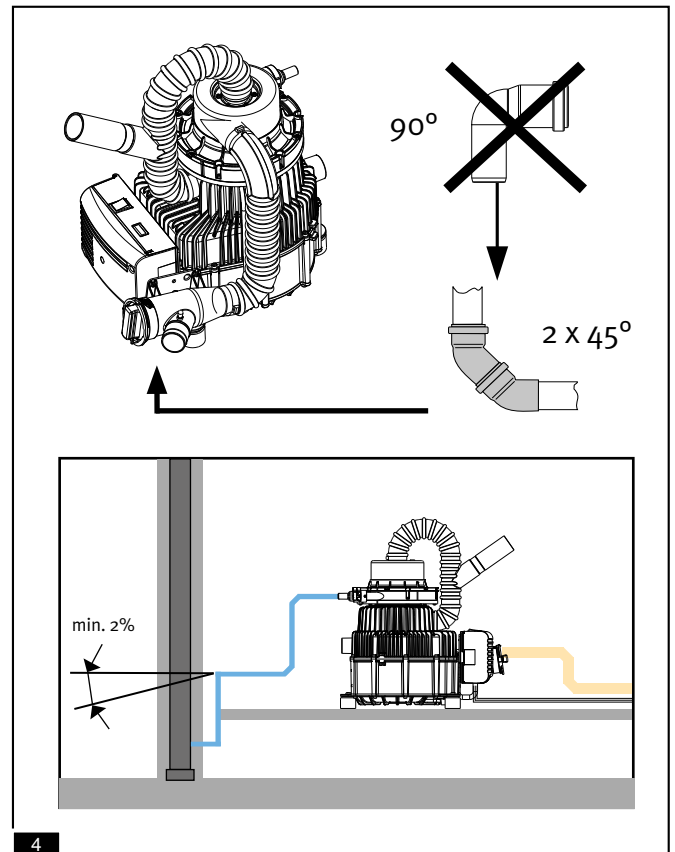

12. Hose connections:

5 See illustration

- 5.1 Connection for the suction hose (from the treatment units):
Ø 40 mm
- 5.2 Connection for exhaust air:
Ø 40 mm
- 5.3 Connection for waste water (clean water discharge):
Ø 15 mm

 **All hose connections must be secured with hose clamps!**
For the exhaust air connections only heat-resistant ($\geq 130^\circ\text{C}$) hose and pipe material must be used.

 **In case of water discharge at the water collector all connections, especially the water discharge pipe, must be checked.**

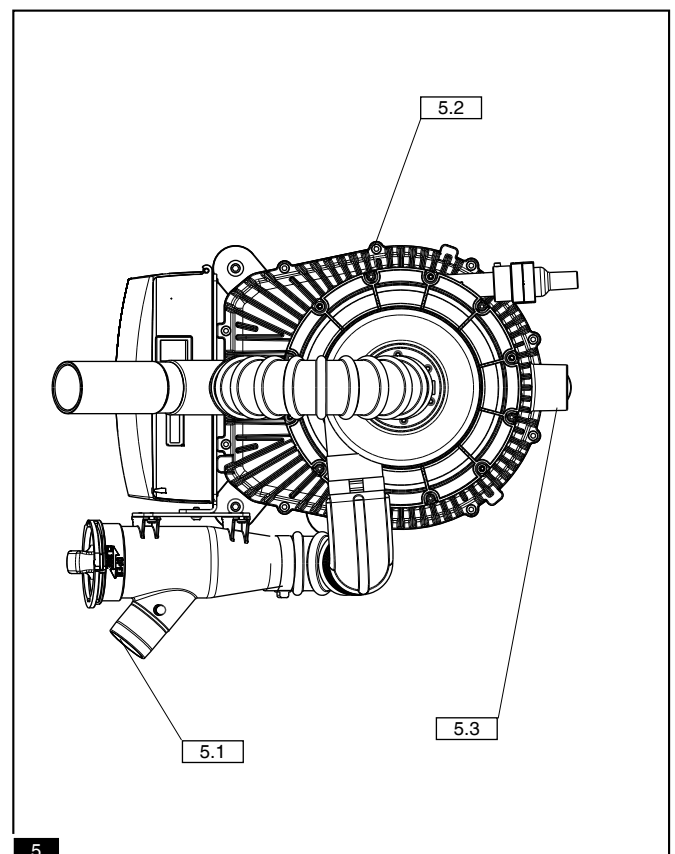

GB

Electrical connections

13. Electrical connections

Mains connection:

The mains connection must only be carried out by a trained electrician.

The electrical installation must be carried out in accordance with applicable local regulations.

Before connecting with the mains, the nominal voltage stated on the type plate on the equipment must be compared with the mains voltage.

The EXCOM hybrid 1 suction system must only be connected to the power supply with the supplied power cable. Extension cables must not be used.

Main switch:

Connection to the mains must be established after the practise's main switch.

1 See illustration

Legend:

A1	control board
C1	capacitor
K1	motor contactor
M1	motor for vac
Q1	protection switch

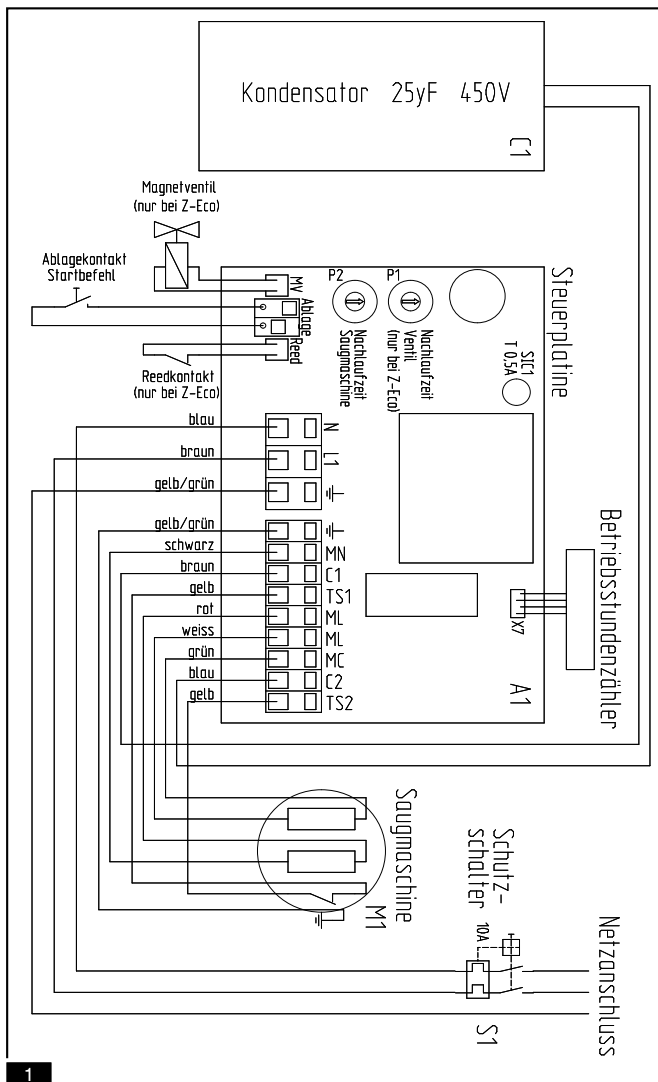

GB

Electrical connections

13. Electrical connections

Hose rest signal:

The control cable for the hose rest signal light is already connected internally by a 2 pole cable, 3 metres long.

The suction system starts when the two contacts are connected. The control cable is to be properly fixed into a junction box.

Follow-up time:

The factory-made follow-up time of the suction system is ca. 60 seconds. By turning the knob P2 on the control board, the running time can be adjusted.

2 See illustration

Legend:

A1	control board
C1	capacitor
K1	motor contactor
Q1	protection switch
W1	power supply
W2	control cable - motor for vac
W3	control cable - support signal
P1	hour meter

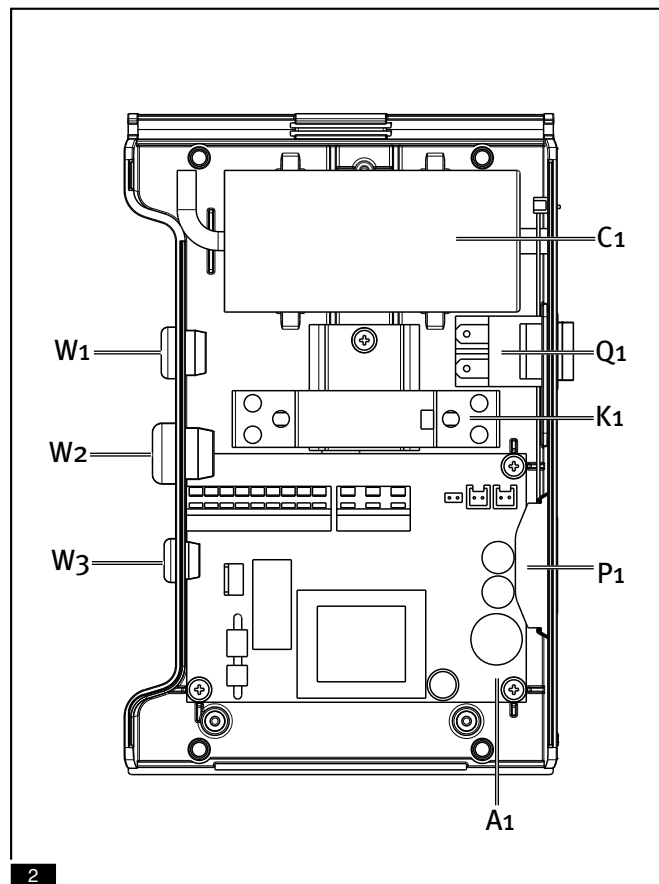

2

GB

Connection ECO II with EXCOM hybrid 1

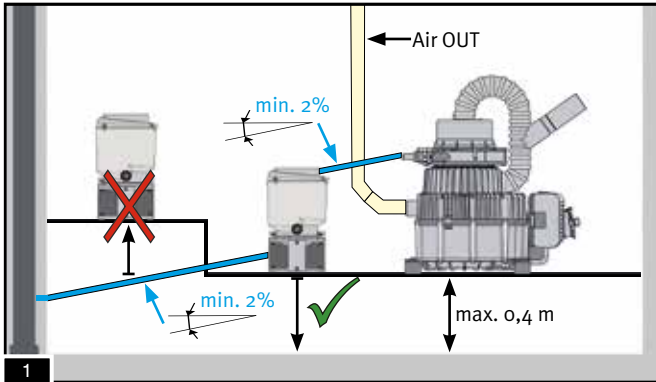

14. Connection of the amalgam separator ECO II with the EXCOM hybrid 1:

1 Connection of the sewerage tubes and pipes

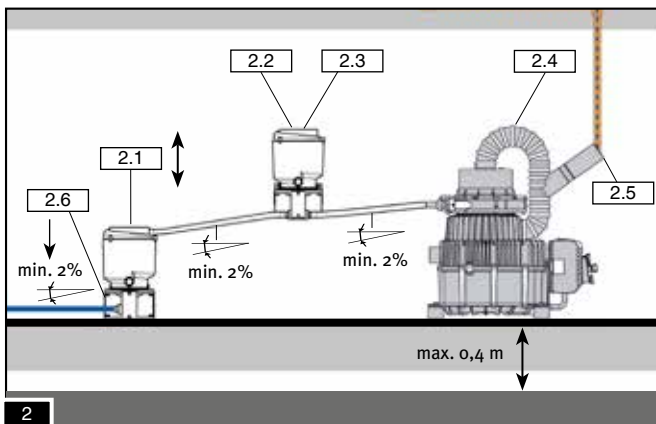

2 Optional installation expansion container

In case of high volumes of liquid and spontaneously fulminating large quantities of water, an expansion container (order no. 40040014) needs to be installed between the suction system EXCOM hybrid 1 and the amalgam separator ECO II.

2.1 amalgam separator

2.2 expansion container

2.3 bleading valve

2.4 suction system

2.5 air in

2.6 water out

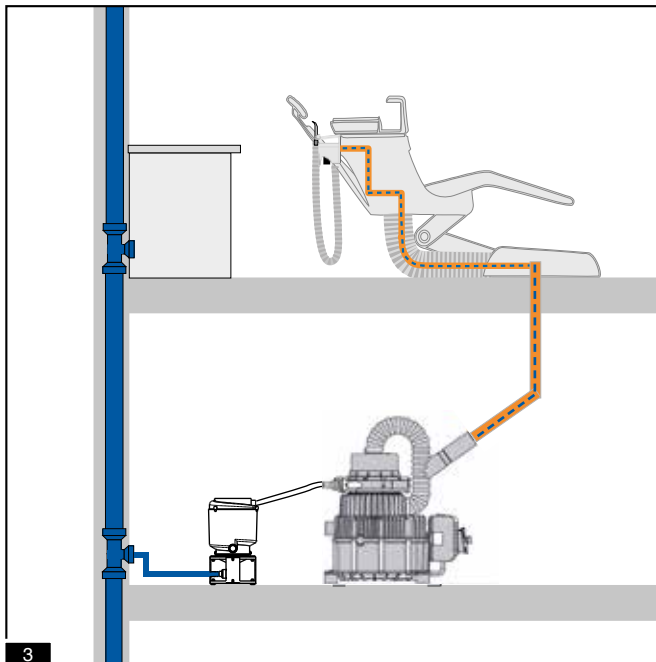

3 ECO II

Maintenance, cleaning and disinfection with GREEN&CLEAN M2

15. Maintenance, cleaning and disinfection:

3 See illustration

Shortly flush spittoon bowl after each treatment!

4 See illustration

Suck some water through all suction hoses after every treatment.

5 See illustration

Twice a day, after having sucked off some water, use the disinfectant for amalgam separators GREEN&CLEAN M2.

6 See illustration

The spittoon bowl should also be rinsed with GREEN&CLEAN M2 twice a day.

Cleaning the prefilter:

- The prefilter must be emptied and cleaned at least once a week. This may also be carried out daily, depending on workload.

7 See illustration

Collect any residues from the prefilter, which may contain amalgam, in the suitable container METASYS ECOCENTER (order no: 40150001), and dispose of it properly with ECOTRANSFORM.

Please go to www.metasys.com to locate your national collection point.

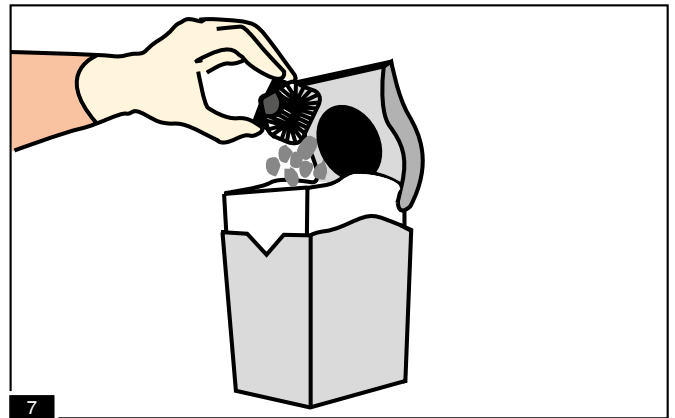
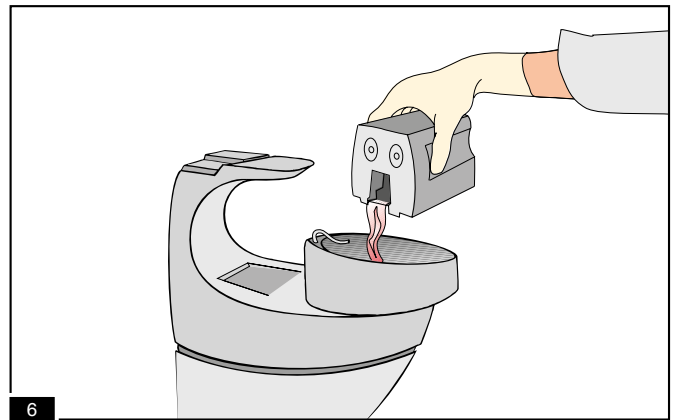
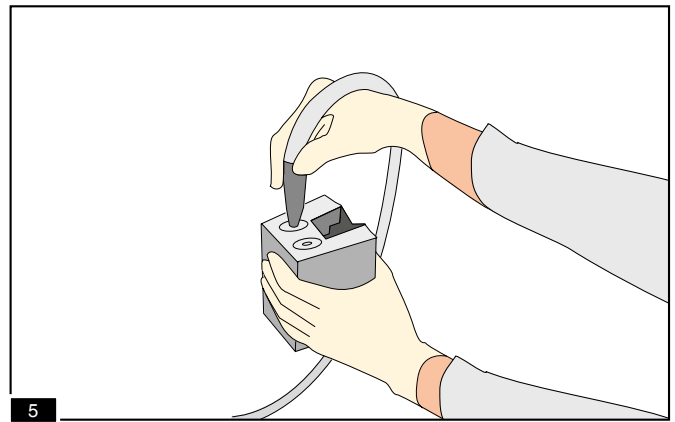
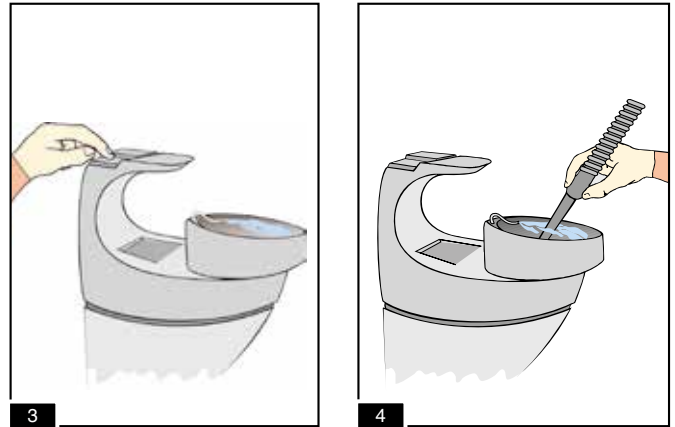

GB



Commissioning

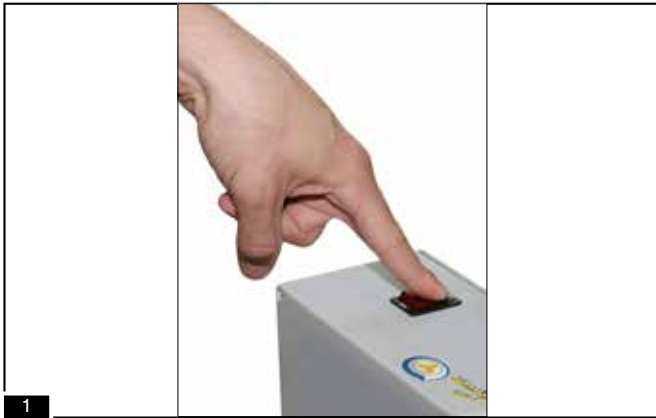

16. Commissioning:

1 See illustration

- Switch on practice and the equipment main switch.



2 See illustration

- Remove the suction hose from its holder.
- Check that all hose connections and other connections in the suction pipe are airtight.

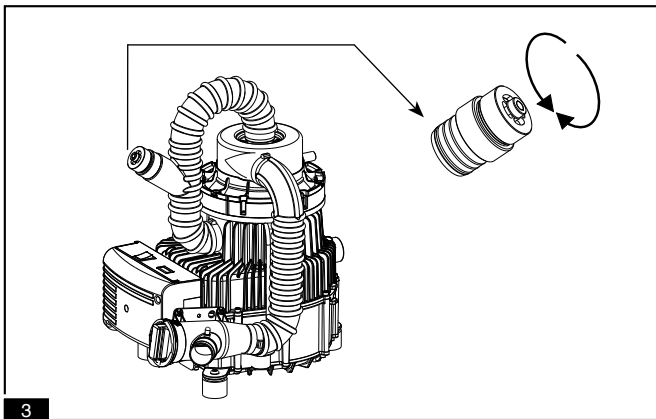

3 **Adjust the air inlet valve** - see illustration

- The suction flow at the large sucker should be at least 300 l/min.
- Adjustments are made by turning the adjustment screw on the air inlet valve whilst measuring the air flow at the large suction tip using a vacuum gauge*.

* Digital manometer Order no.: 40400005

Protective covering for manometer Order no.: 40400006

Negative pressure with air inlet valve: 180 (-20) mbar

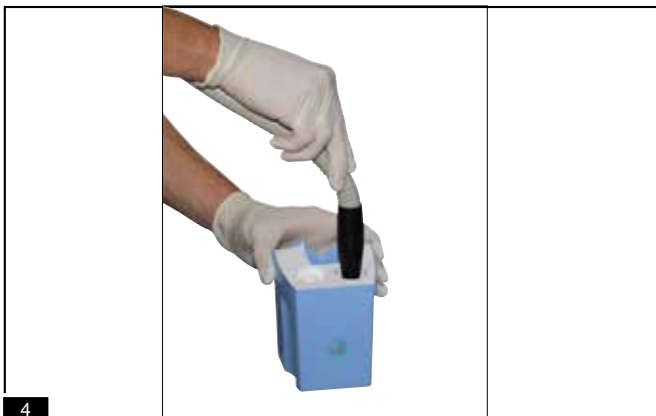

4 See illustration

- Suck 3 litres of water and check that the EXCOM hybrid 1 central suction system is operating correctly.
- Undertake electrical safety checks as required by local legislation, and record that the checks have been made.

Maintenance

Disposal of the equipment

17. Maintenance:

5 See illustration

The following filters must be checked and cleaned every week:

- The filter in the hose rest or the suction hose (not illustrated).
- The filter in spittoon bowl outlet and the spittoon valve 5.1
- The base filter 5.2

Cleaning the filters:

The prefilters must be cleaned at least once a week. However, depending on the method of working, this may be necessary every day.

A clogged prefilter is perceivable by a reduction of suction power.

Exhaust air filter:

The optional exhaust air bio filter must be changed at least once a year.

18. Disposal of the equipment:



The devices may be contaminated. Please inform the disposal company of this so that the necessary precautions can be taken.

Disposal of amalgam separator components, such as sieves, filters, hoses etc., must also comply with local regulations.

Uncontaminated plastic components of the suction system may be recycled.

The built-in control unit, electronic circuit boards and components may be disposed of as electro-technical scrap. Other metal components may be disposed of as ordinary metal scrap.

If the device is returned, for example to the dealer or METASYS Medizintechnik GmbH, all connections must be sealed so that they are watertight.

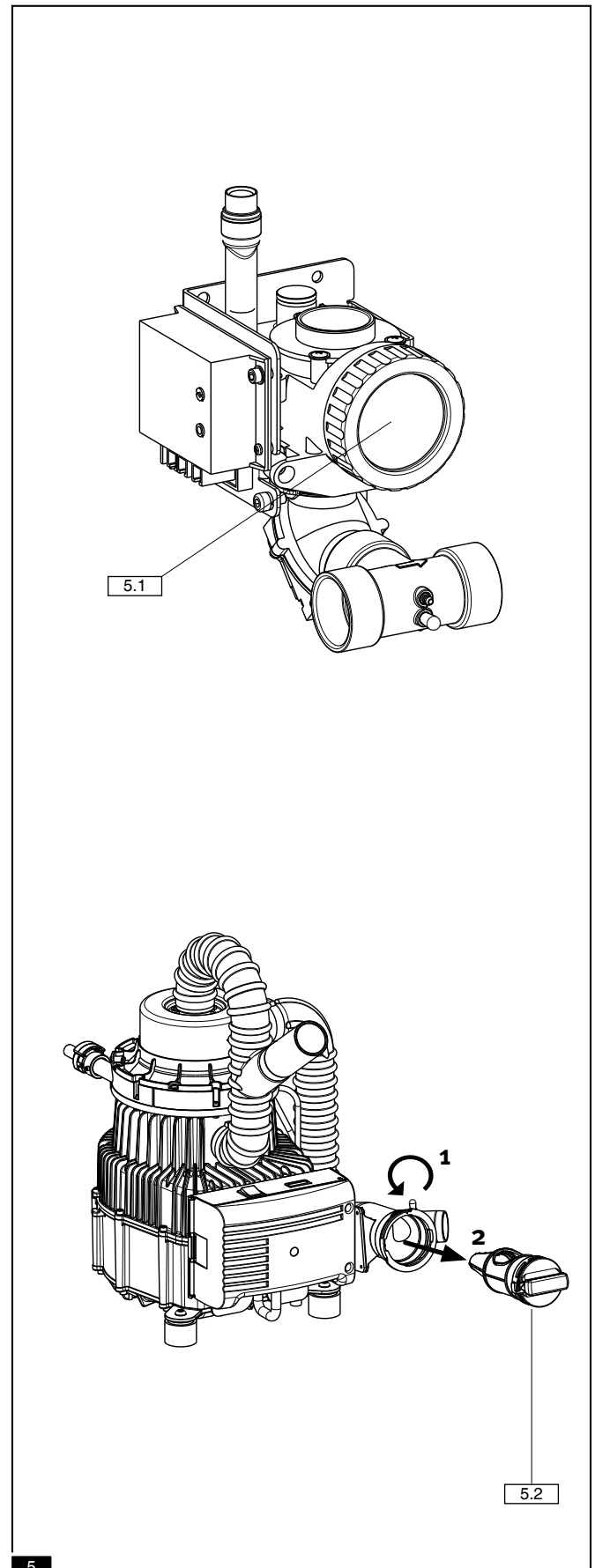

GB



Austria

METASYS
Medizintechnik GmbH
Florianstraße 3
A-6063 Rum bei Innsbruck
☎ +43 / (0) 512 / 20 54 20-0
☎ +43 / (0) 512 / 20 54 20-7

Germany

METASYS
Medizintechnik GmbH
Ahornstraße 19
D-85614 Kirchseeon
☎ +49 / (0) 2236 / 37 42 42
☎ +49 / (0) 2236 / 37 42 41

France

METASYS France S.a.r.l.
9, bd E. Michelet
F-69008 Lyon
☎ +33 / (0) 4 / 37 90 22 15
☎ +33 / (0) 4 / 37 90 22 47
e-mail: info@metasys.fr
www.metasys.fr

email: info@metasys.com

www.metasys.com

Italy



METASYS GROUP
DENTAL ECO SERVICE ITALIA S.R.L.
Florianstraße 3
A-6063 Rum bei Innsbruck
☎ +39 / 045 / 981 4477
☎ +39 / 045 / 981 4475
e-mail: desitalia@metasys.com